

Struck Corporation
W51 N545 Stuck Lane
PO Box 307
Cedarburg, WI 53074

Phone: (262) 377-3300
Email: parts@struckcorp.com
Text: 262-233-4292

Abbreviated parts list for the Peerless Transaxle 2338

All prices are subject to change daily. Thank you.

Part#	Description	Pricing
792016	Snap Ring - Ref. #2	\$2.01
792001	O-Ring, Ref #3	\$3.80
792049	Drive Pin - Ref. #4	\$7.83
784093	Shift Lever Housing - Ref. #5	\$33.44
784094	Shift Lever Keeper - Ref. #6	\$35.15
784004	Shifter Fork - Ref. #11	\$36.25
780042	Thrust Washer - Ref. #16	\$5.14
792005	Hex Head Cap Screw, 1/4-20 x 2-1/2, Ref. #17	\$1.95
778033A	Ring Gear - Ref. #19	\$137.85
786027	Drive Block - Ref. #21	\$9.38
778094	Bevel Pinion - Ref. #22	\$36.20
776029A	Brake Shaft and Gear - Ref #23	\$113.85
792017	Snap Ring - Ref. #24	\$1.96
780053	Bushing - Ref. #28	\$8.69
784074	Shifter Gear - Ref. #29	\$13.20
788023	Gasket, Case & Cover - Ref. #30	\$6.03
788022	Gasket, Shift Lever Housing, Ref #31	\$4.22
778019A	Shifting Gear (3rd & 4th) #32	\$79.42
778095	Bevel Gear - Ref. #34	\$55.11
778037	Idler Gear, Ref. #35	\$42.69
786024	Spacer - Ref. #37	\$4.05
792018	Snap Ring, Ref. #38	\$2.00
778024A	Input Shaft Spur Gear - Ref. #40	\$25.19
788021	Oil Seal & Retainer Assembly, Includes #45 , Ref. #42	\$24.59
778036	Output Gear - Ref. #43	\$43.40
776028	Output Pinion, Ref. #44	\$101.50
788008	Oil Seal - Ref. #45	\$8.71
772016A	Transaxle Cover Assembly (includes #54, 55, 57, 59, & 63) Ref. #47	\$502.00
770012	Transaxle Case Assembly (includes #54, 55, 57, & 63) Ref. #48	\$602.00
792007	Socket Heads Cap Screw, 5/16-18 x 1, Ref. #49	\$2.88
792037	Hex Head Sems Screw, 5/16-18 x 1, Ref. #51	\$5.20
780049	Needle Bearing - Ref. #54	\$22.50
780001	Washer - Ref. #61	\$3.09
776031	Shaft and Pinion - Ref. #62	\$79.50
776030	Reverse Idler Shaft - Ref. #64	\$16.25
786025	Reverse Idler Spacer - Ref. #65	\$13.51
778038	Spur Gear (22 teeth) - Ref. #67	\$43.20
780041	Bushing - Ref. #71	\$10.25
780051	Thrust Washer - Ref. #74	\$5.09
780075	Thrust Washer - Ref. #76	\$11.46
780107	Washer - Ref. #77	\$5.09

Shipping costs will be added to your order amount. We accept Visa, Mastercard, American Express, Discover, Pay Pal and checks with a 2-week waiting period.

A-2147

Model 2338-A

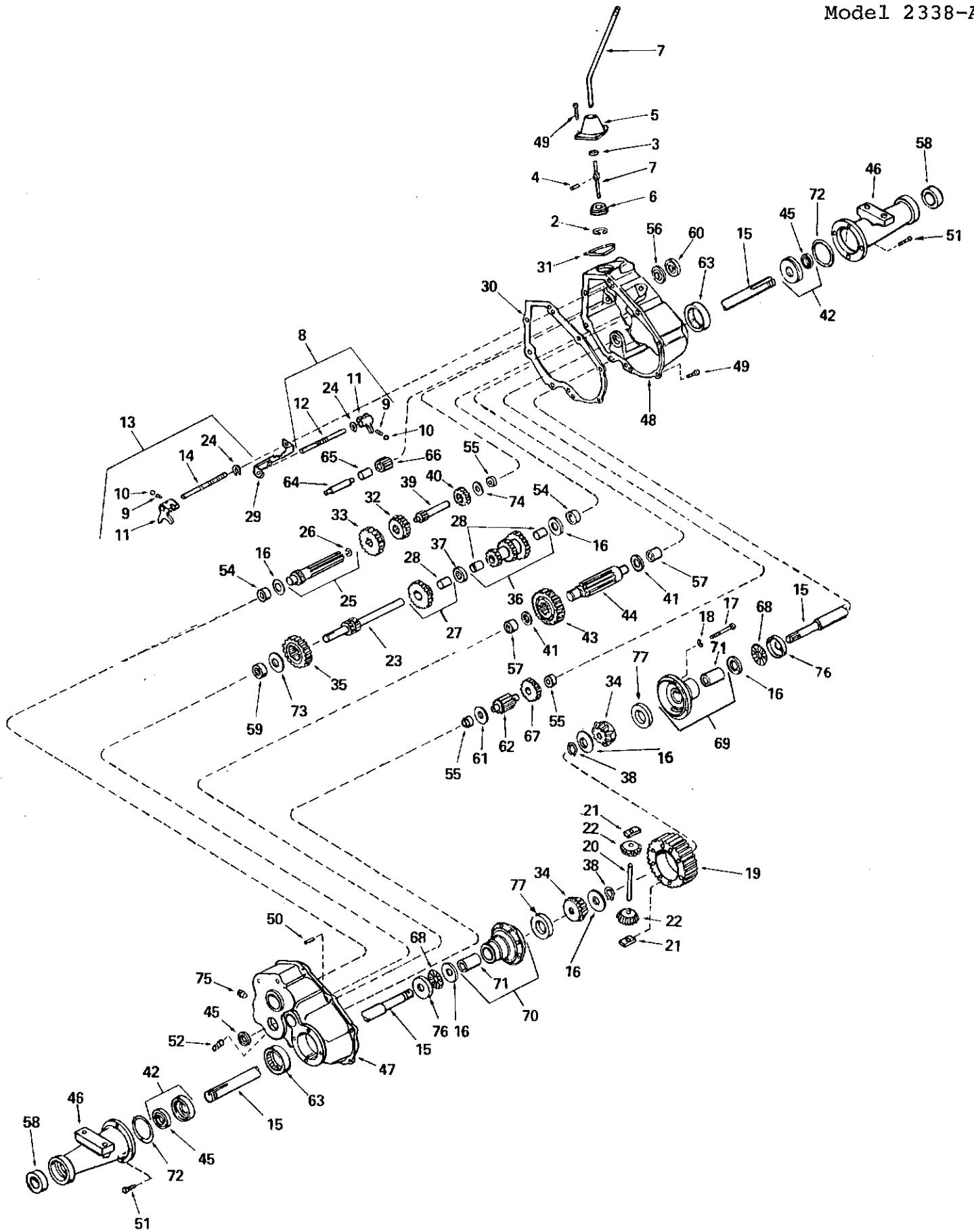

CHAPTER 5. FOUR-SPEED TRANSAXLES

#2338

SECTION 1. 2300 SERIES

CAUTION

DECLUTCHING IS REQUIRED WHEN SHIFTING
TO AVOID GEAR CLASHING AND DAMAGE.

A. GENERAL

The 2300 series transaxles have a four speed forward and one reverse transmission.

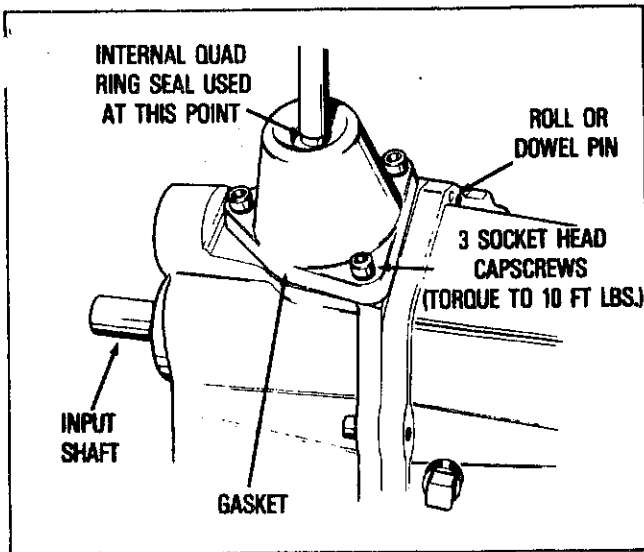
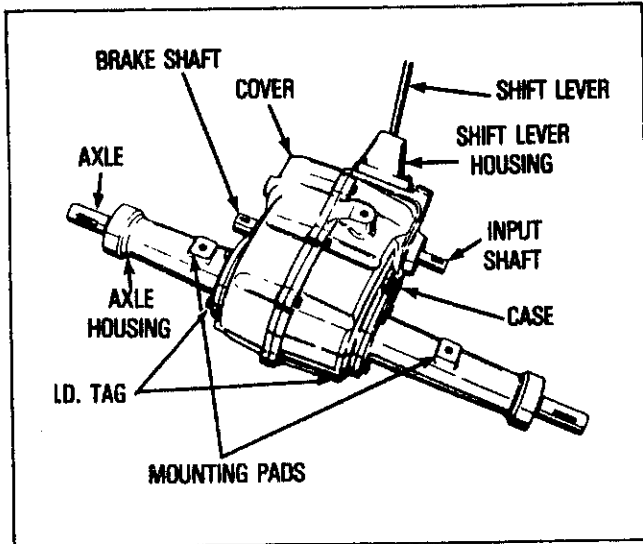

B. DISASSEMBLY

1. Position the shifter forks in neutral before disassembly.

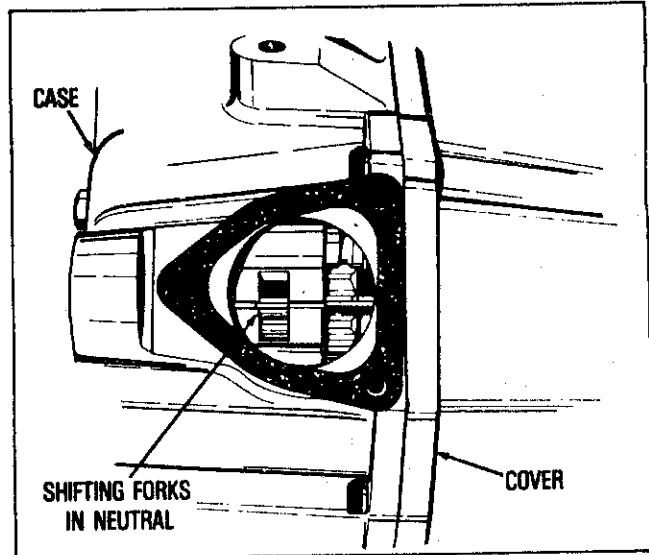

2. Remove both axle housings, and use the exposed axle as a ram to separate the seal retainers from the case and cover.
3. When disassembling the rest of the unit, it should be held so that;
 - a. It lies on the cover, properly blocked up, so that no weight rests on the brake shaft.
 - b. The cover should sit rigidly so that the removal of parts can be done in a systematic step by step procedure.
 - c. It will not fall causing an accident or injury.
4. Oil seals are of the double lip type so sleeve protectors do not offer much protection when removing them. Upon replacement, new seals should be used.

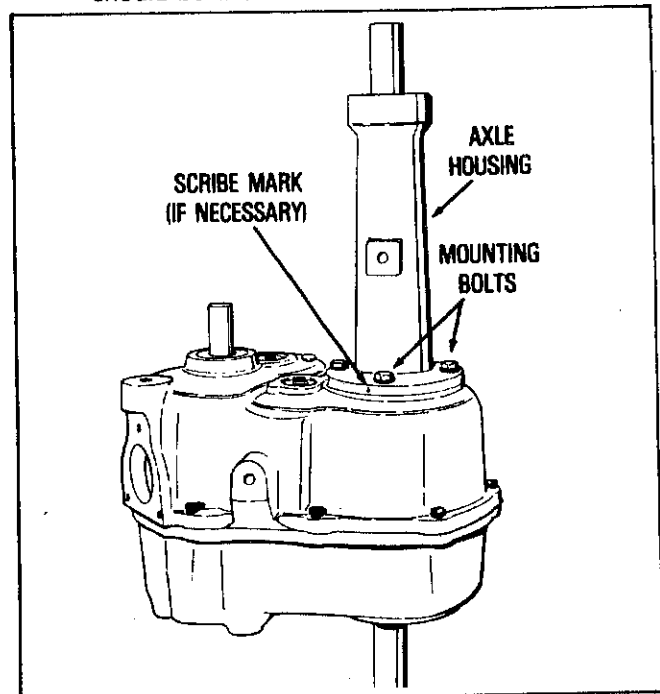

5. Tap dowel pins into the cover and remove eight socket head capscrews.

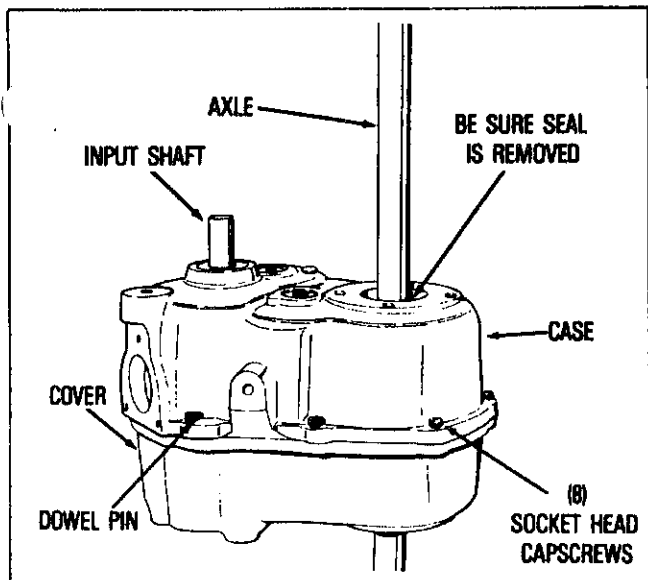

6. To separate the case from the cover:
- Lift the case 1-1/2 to 2" above the cover.
 - Tilt the case so that the shift rods will clear edge.
 - Rotate the case so that boss hidden inside will clear gears, then lift free of the differential.

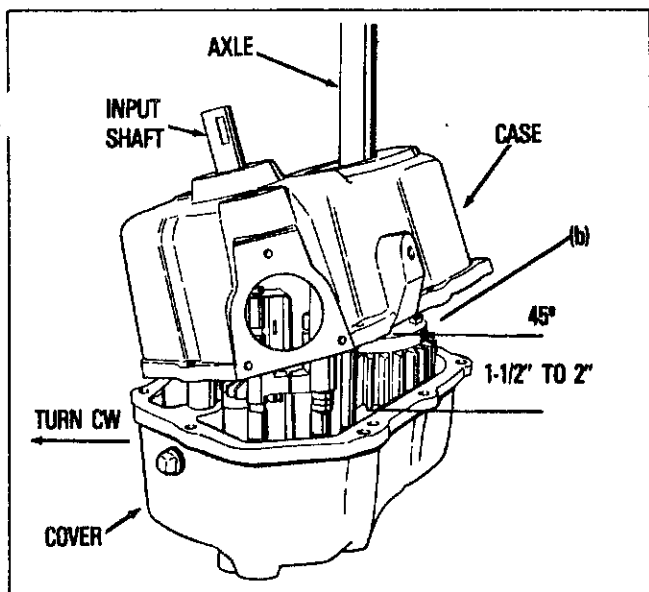

7. Remove thrust washer and three gear cluster from brake shaft, noting whether the cluster has a sloppy fit.
- To service the cluster bushings, refer to Chapter 11.
 - Inspect gear teeth for wearing, chipping or breaks. Wear or chipping on the bevel area only, indicates shifting while the equipment is in motion.

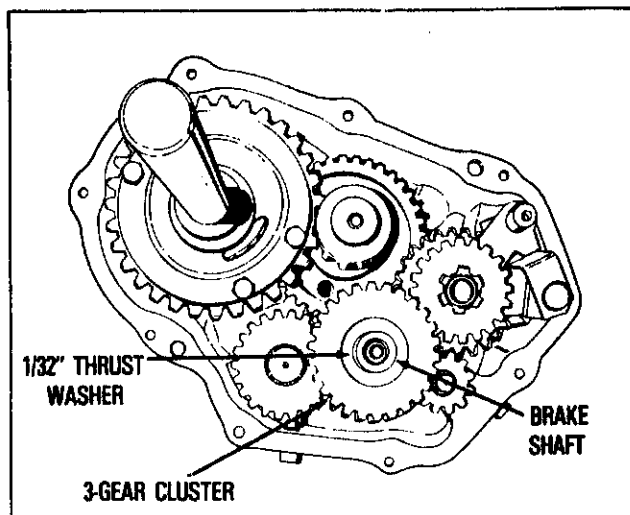

8. Remove the reverse idler gear, spacer and shaft from boss in cover.

Note that the spacer goes between the gear and the cover, and that the gear bevels go down.

Excessive wear on teeth bevels indicates improper shifting technique.

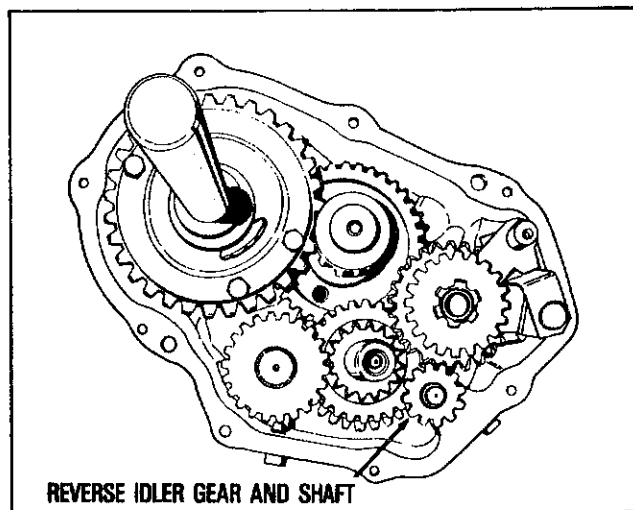

9. Lift out the shifter assembly. Service of this unit is described in Chapter 10.

If it is evident that the shifter assembly needs no further teardown, place it aside in a clean place, intact, for easy reassembly.

10. Remove the low gear and shaft, and splined spur gear. Separate gear and shaft. Note that NO thrust washer is between the gear and case.

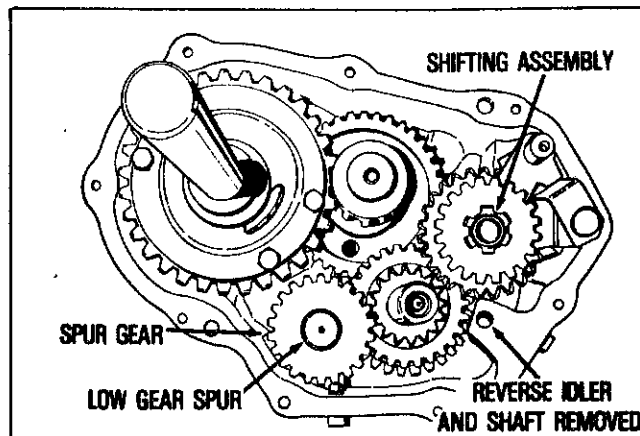

11. Remove the two gear cluster and spacer from the brake shaft.

12. Lift the differential unit out of the cover.

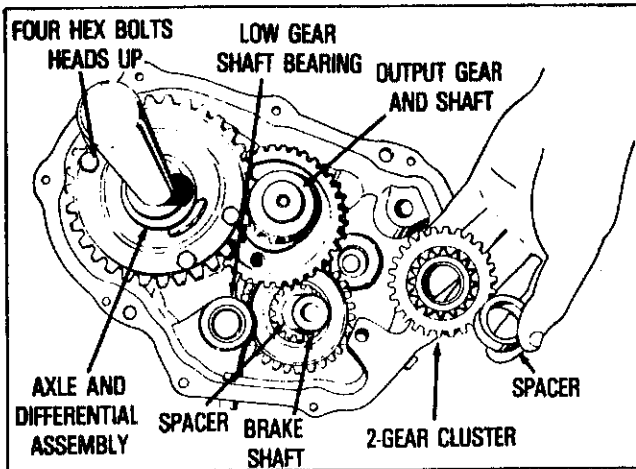

13. Remove the output shaft and gear and thrust washer from each end of the shaft.

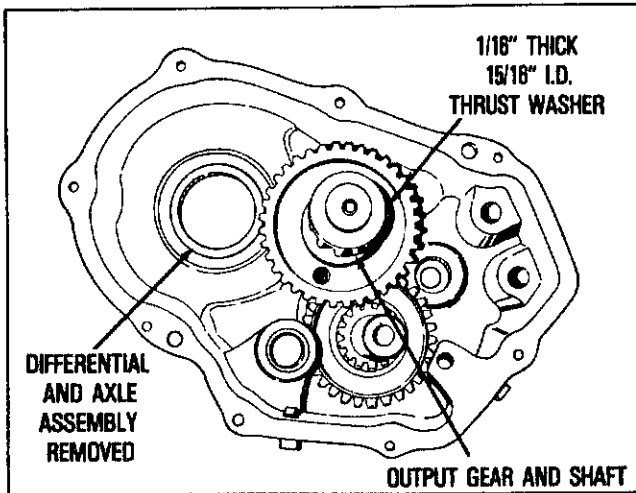

14. Remove the brake shaft.

Note that the brake shaft idler separates from the shaft. If separated, be sure that when re-assembled, the idler gear chamfers are away from the cover.

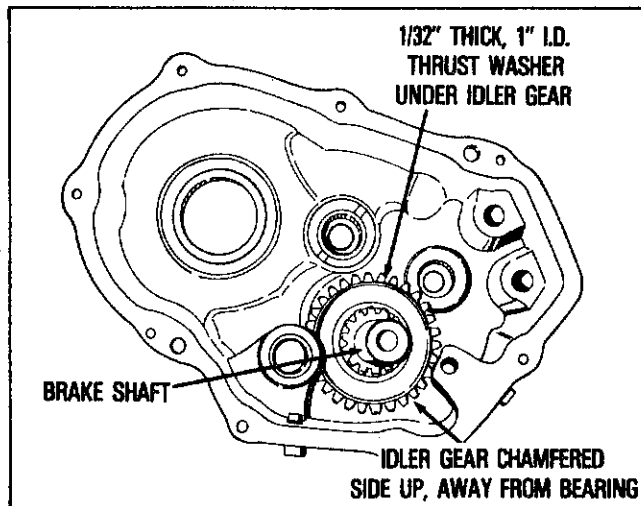

15. Remove input shaft from case by tapping with a non-metallic hammer.

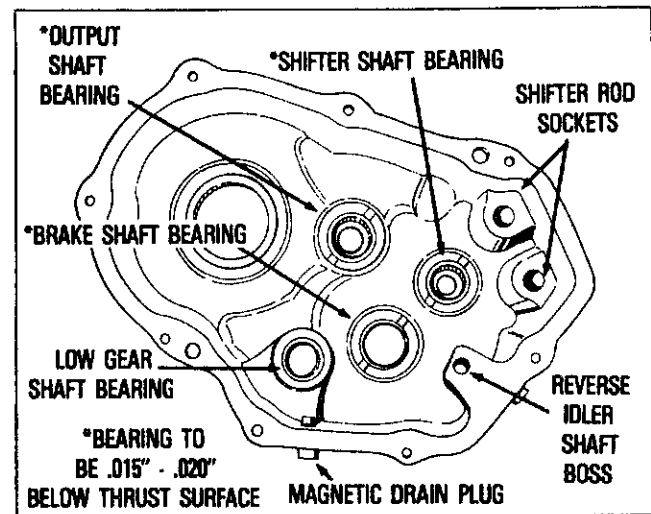
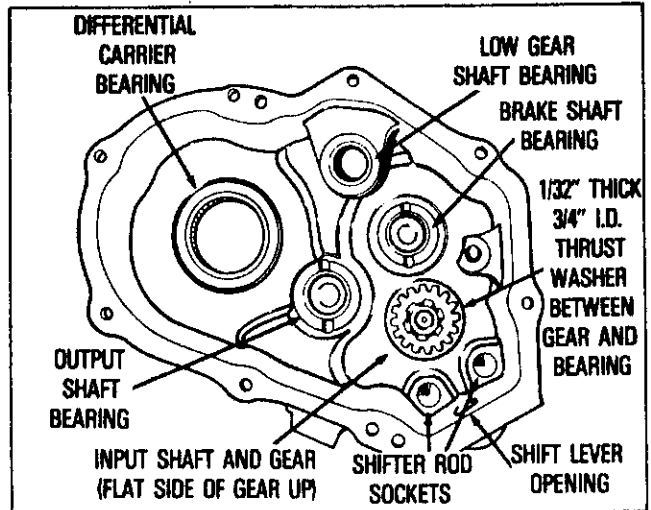

C. INSPECTION AND REPAIR

1. Gears.

a. Check bevels for evidence of galling due to improper shifting.

NOTE: Peerless Transaxles must be stopped for shifting.

b. Check face of teeth for wear. Large shiny areas indicate too much tooth contact and possible excessive wear. Replace gears indicating damage or excessive wear.

2. Shafts and Axles.

a. Check surface for rust, pitting, scratches or wear.

b. Check keyways, splines, threads, and grooves for wear. Replace parts if worn or damaged beyond a refinishable state.

3. Case and Cover.

Check for cracks, stripped threads, metal chips, flat sealing surfaces and rust. Clean out any rust. Replace parts if any damage is found that cannot be repaired.

4. Thrust Washers and Spacers.

Check for shininess indicating wear. Replace if wear is evident. Try to determine cause of thrust washer wear such as: lack of end play due to re-use of gasket, or use of wrong thrust washer.

5. Shifting Assembly.

Refer to Chapter 10.

6. Gaskets.

Replace all gaskets.

7. Oil Seals.

It is a good habit to replace all seals. It is necessary to replace all double lip seals. See Chapter 1, paragraph F, "OIL LEAKS, SEAL AND GASKET SERVICE".

8. Bearings and Bushings.

Refer to Chapter 11.

D. ASSEMBLY

1. Install input shaft in case. Use a soft mallet to seat shaft and gear completely. Often, binding in the assembled unit can be traced to a partially installed input shaft.

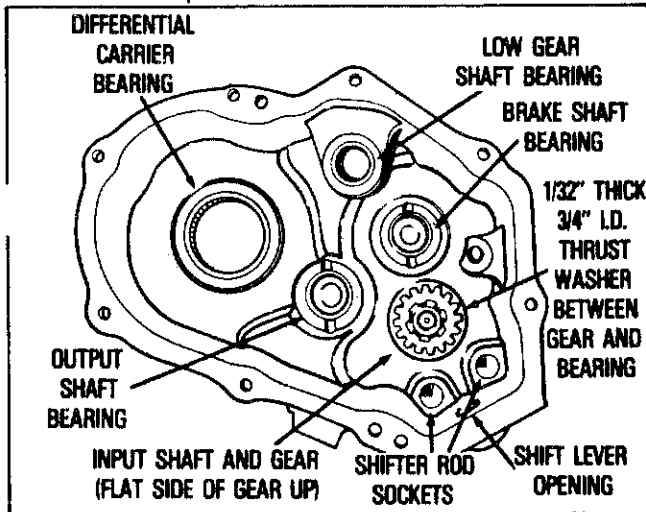

2. Center one 1/32" thick by 1" I.D. thrust washer on the cover brake shaft needle bearing, then install the brake shaft and gear, (chamfer side away from cover).

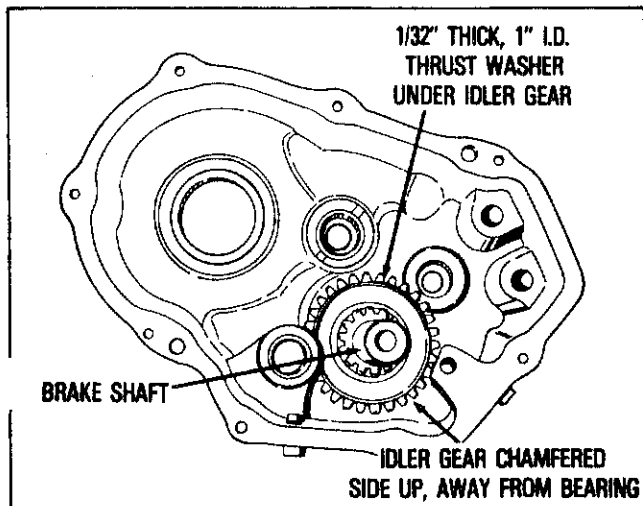

3. Install the output shaft and gear after centering a 1/16" thick by 15/16" I.D. thrust washer on each end of the shaft.

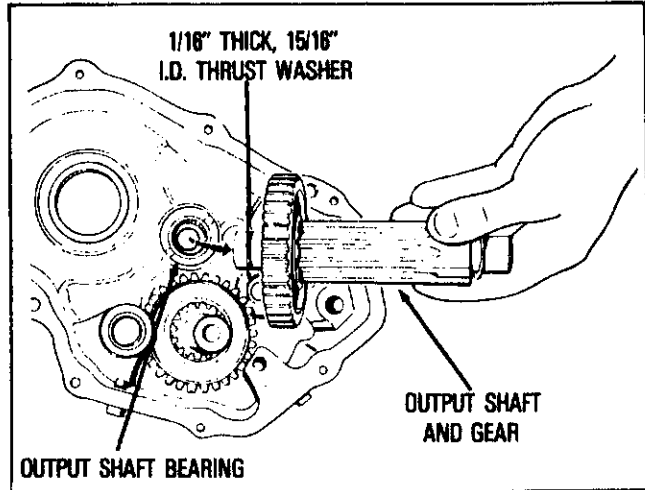

4. Insert the differential assembly into the cover. Note that the four bolt heads should be out away from the output gear.
5. Install the two gear cluster and spacer on the brake shaft.

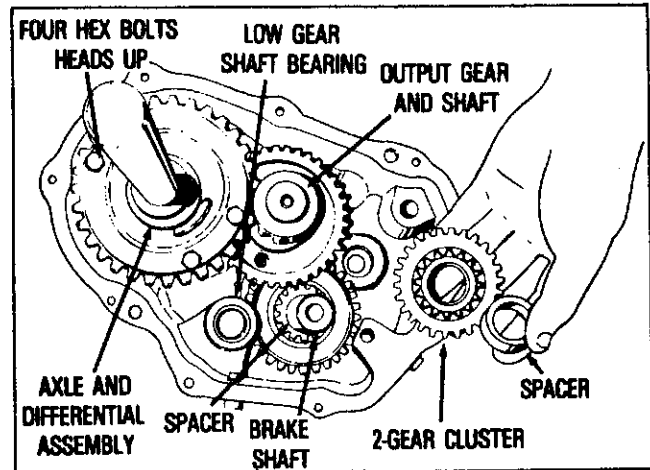

6. Install a 1/16" thick by 3/4" I.D. thrust washer, gear and low gear idler shaft in cover. Do not put a thrust washer on the exposed end of this shaft. Be sure the small gear meshes with the larger gear of the two gear cluster.
7. Center one 1/32" thick by 7/8" I.D. thrust washer on cover shifter shaft bearing.

8. Install shifter assembly as a unit into the cover.

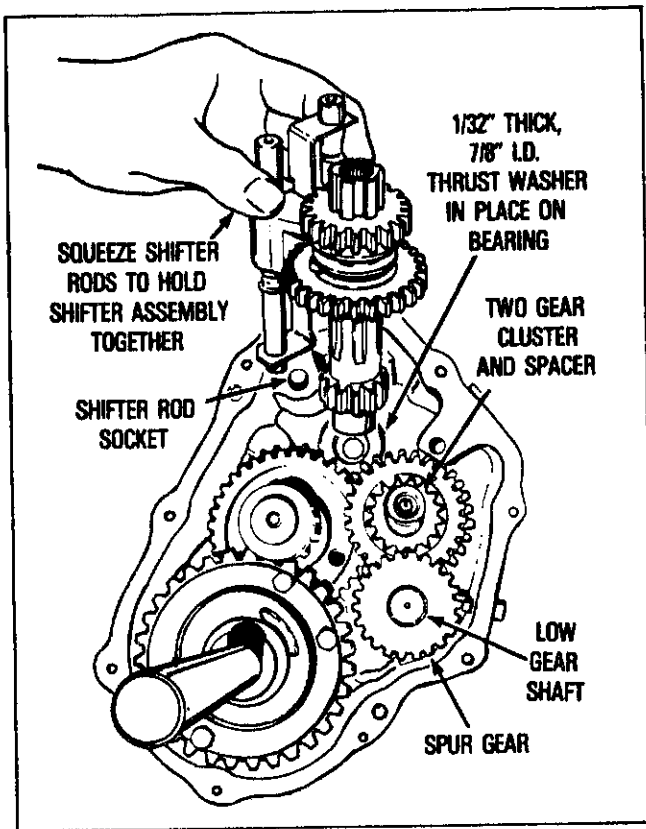

9. Install the reverse idler shaft, spacer and gear into the cover. The beveled side of the idler gear should be down into the cover.

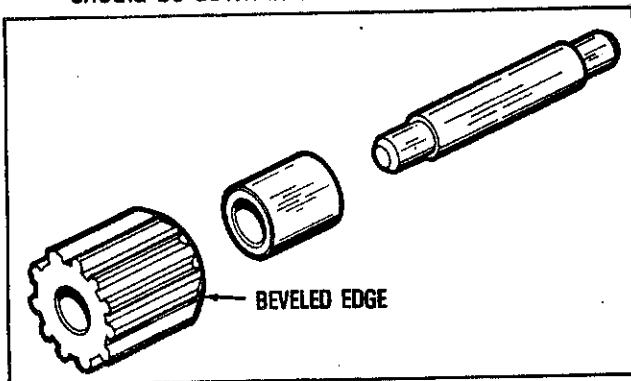

10. With the small gear of the three gear cluster toward the spacer, install the three gear cluster and other 1/32" thick by 7/8" I.D. thrust washer on the brake shaft.

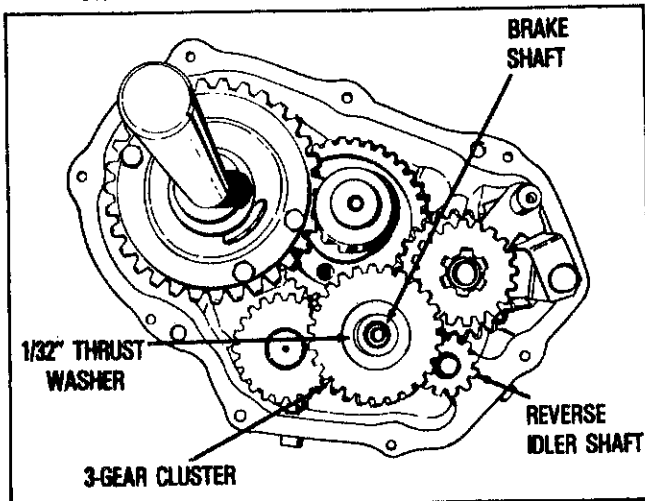

11. Position the gasket on the cover sealing surface, then install case over the differential shaft. Be sure the boss goes under gears and that edge of the case goes over the shaft rods in the opposite manner from which it was removed.

12. Once in position, if case hangs 1/2 to 1" high, turn the input shaft to get gears to mesh. The case should drop about 1/4" from closing.

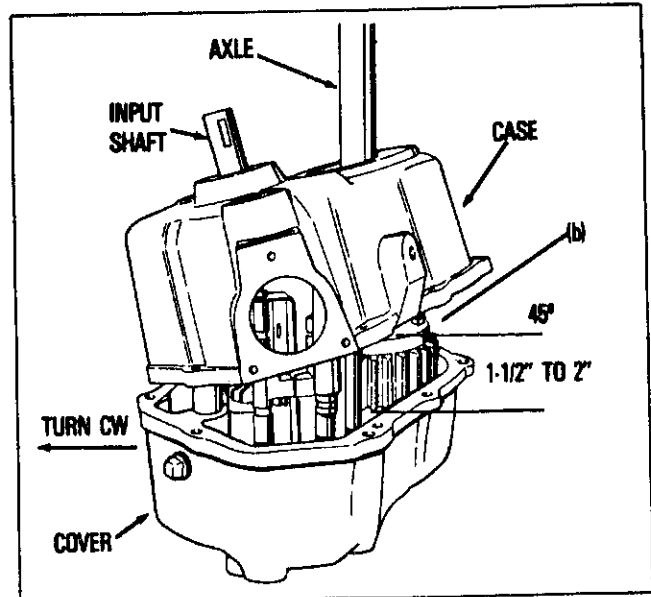

13. Use a pair of needle nose pliers on the shifter stop on each shifter fork to agitate the shifter rod ends into their machined recesses in the case.

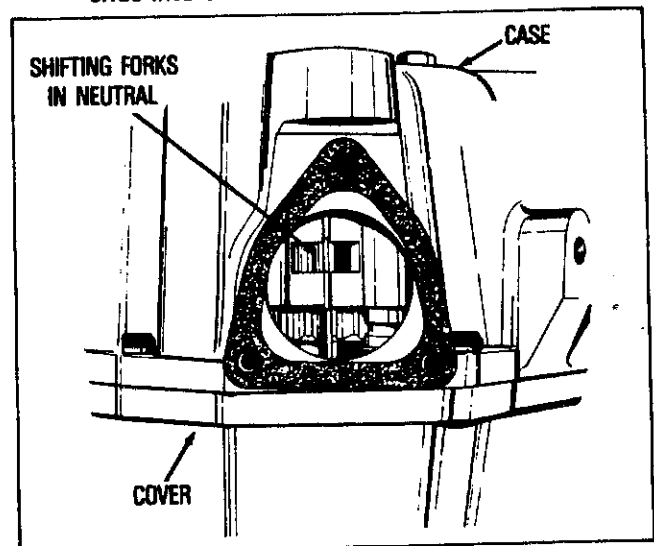

14. Align the case and cover with the two dowels, then install and tighten the eight socket head cap screws. Torque screws to 10 ft. lbs. Unit can now be placed flat on the work bench.

Place seal retainers and new seals in position.

CAUTION: Sleeves must be used to protect seals, especially axle ends or where wheels attach.

15. Install new "O" rings on seal retainers and position axle supports to case and cover. Be sure mounting pads face in the same direction as when removed. Install capscrews and torque to 13 ft. lbs.

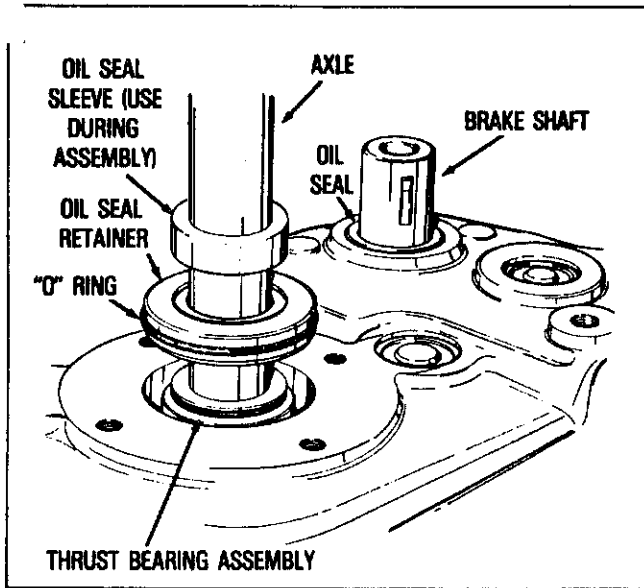

16. Install shift lever housing and new gasket.

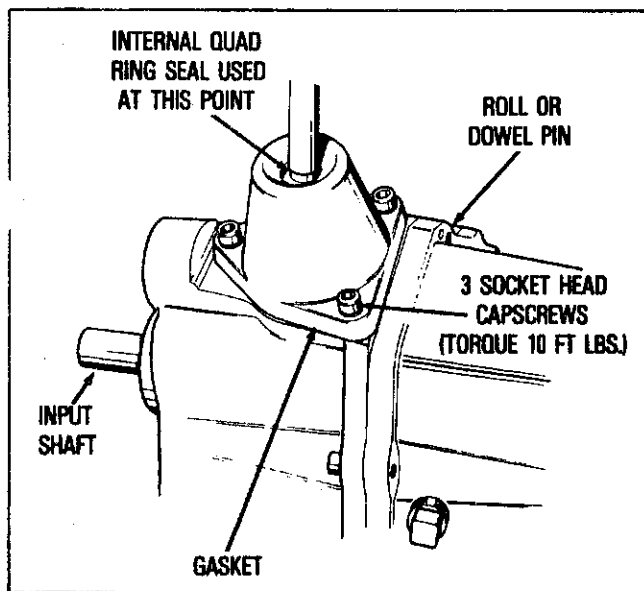

E. TESTING AND LUBRICATION

1. For testing, refer to Chapter 1, Paragraph H.
2. For proper lubrication type and amount, refer to page 1-6.

One quart oil SAE90EP